

Low Frequency Mounts



Low Frequency Mounts' unique design bonds a steel spring inside a matrix of oil/ ozone-resistant neoprene. The springs absorb low frequency vibrations, slowing and passing them on to the resilient neoprene. This material—made even more stable by the springs—interrupts the sound path, prevents noise amplification caused by sounding board effects, and stops vibrations from being transmitted to the floor or work surface.

Low Frequency Mounts are made for your toughest vibration applications. They tame the effects of paint mixers, air conditioning units, air compressors and more, indoors and out. There are models for loads from 50 to 4,700 lbs. which exhibit 3.5 Hz natural frequency at maximum load.

Typical Mounting Application

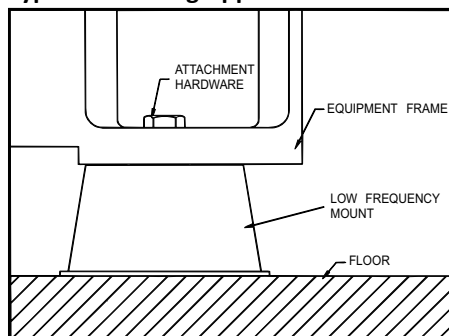

Low Frequency Mounts

Dimensions and Specifications

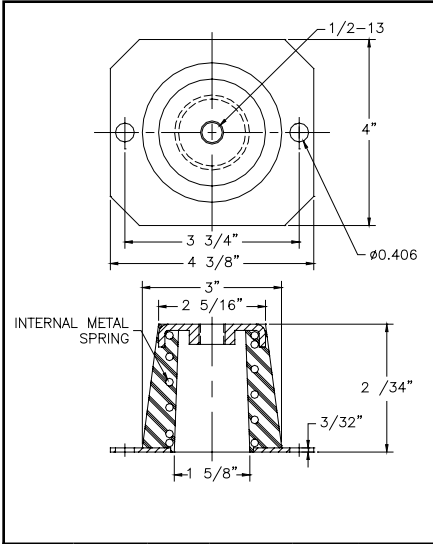

| Part No. | Color Code | Min. Load (lbs) | Approx. Defl. | Max. Load (lbs) | Approx. Defl. |
|----------|------------|-----------------|---------------|-----------------|---------------|
| 61503 | Yellow | 50 | 0.1" | 400 | 0.9" |
| 61505 | Green | 100 | 0.1 | 1100 | 0.9 |
| 61507 | White | 250 | 0.1 | 2600 | 0.9 |

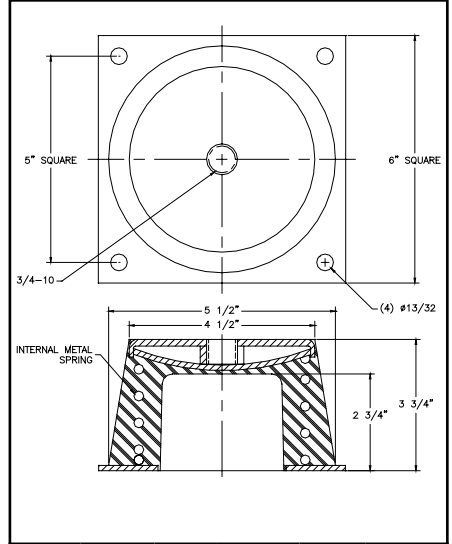
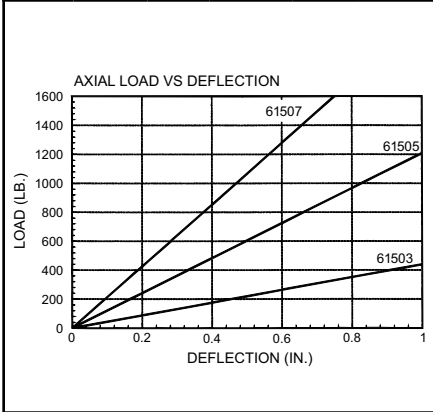

| Part No. | Color Code | Min. Load (lbs) | Approx. Defl. | Max. Load (lbs) | Approx. Defl. |
|----------|------------|-----------------|---------------|-----------------|---------------|
| 61060 | Yellow | 150 | 0.1" | 1800 | 1" |
| 61062 | Green | 500 | 0.15 | 3100 | 0.9 |
| 61063 | White | 1200 | 0.2 | 4700 | 0.8 |

