

Machine Leveling Mounts

Drawing and Features

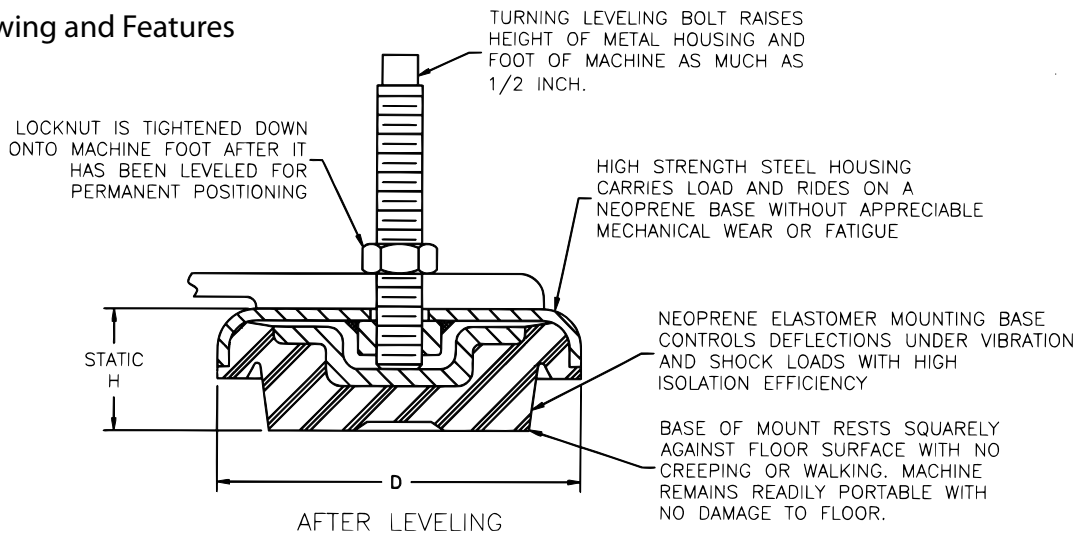

Dimensions and Load Ratings

Part Number	Min. Load (lbs.)	Max. Load (lbs.)	Bolt Size x Length (in.)	Diameter 'D' (in.)	Static Height 'H' (in.)
52220	30	150	3/8-16 x 3	3-1/8	1-1/2
52221	55	250	3/8-16 x 3	3-1/8	1-1/2
52221-1	100	500	3/8-24 x 3	3-1/8	1-1/2
52222	100	500	3/8-16 x 3	3-1/8	1-1/2
52223*	300	1000	1/2-13 x 5	4-3/4	1-1/2
52224	300	1000	1/2-13 x 5	4-3/4	1-1/2
52225*	500	4500	3/4-10 x 5	6-1/4	1-5/8
52226	500	4500	3/4-10 x 5	6-1/4	1-5/8
52227*	4000	13000	1-14 x 8	9	2-1/2
52229*	4000	13000	1-14 x 8	9	2-1/4
52231	4000	13000	3/4-10 x 4	9	2-1/4
52232	4000	13000	3/4-10 x 8	9	2-1/4
52211	4000	13000	3/4-16 x 4	9	2-1/4

Metric Series

Part Number	Min. Load (kgs.)	Max. Load (kgs.)	Bolt Size x Length (mm)	Diameter 'D' (mm)	Static Height 'H' (mm)
52221-1-M10	45	230	M10x1.5 x 80	80	38
52224-M12	135	450	M12x1.75 x 130	120	38
52226-M20	230	2040	M20x2.5 x 130	160	41
52229-M24	1815	5900	M24x3.0 x 180	230	57
52248-M30*	3500	11500	M30x3.5 x 200	315	70

Normally supplied with hex head bolt

*Supplied with square head bolts

Special bolt lengths, diameters, and reducer bushings are available. Consult factory for more information