

# Spring Mounts

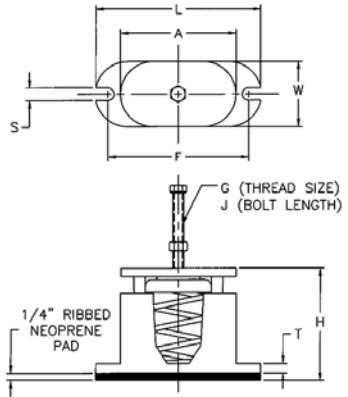
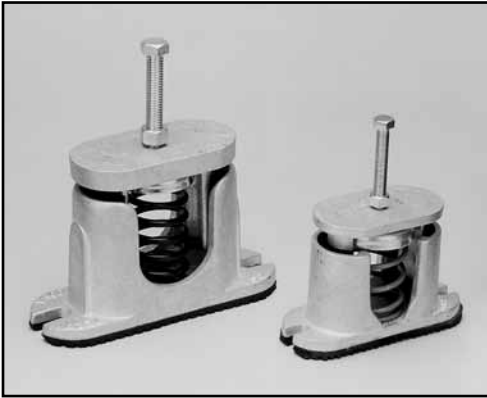

Tech Products' spring mounts with aluminum housings are durable enough to handle most of the applications where steel housings are used. The aluminum housing is more weather resistant and lighter. The cast aluminum allows for higher quality thread integrity. The ribbed neoprene pad provides a non-skid base, and neoprene stabilizer pads are included in the housing to control lateral motion. All aluminum housed mounts include one spring with load ratings as high as 1300 lbs.

Part No.	Spring Color	Max. Load (lbs)	Static Defl.	L	W	H	A	F	G	J	S	T
52811	Purple	40	1.3"	5.69	2.25	3.88	4.00	5.00	3/8-16	3.00	0.44	0.31
52812	Blue	60	1.3"									
52813	Orange	100	1.3"									
52814	Brown	165	1.2"									
52815	Black	260	1.0"									
52816	Yellow	370	0.8"									
52817	Red	450	0.5"									
52818	Green	700	0.5"									
52841	Pink	85	1.36"	7.75	2.63	5.06	5.13	6.56	1/2-13	3.50	0.56	0.38
52842	Black	115	1.31"									
52843	Blue	170	1.28"									
52844	Yellow	225	1.26"									
52845	Brown	325	1.23"									
52846	Red	450	1.22"									
52847	Purple	600	1.17"									
52848	Orange	750	1.06"									
52849	Green	900	1.02"									
52850	Gray	1100	0.83"									
52851	White	1300	0.74"									