

Machine Leveling Mounts



Whenever you need to protect heavy production equipment from shock and vibration, this rugged series of Leveling Mounts will do the job to your full satisfaction.

Their no-walk, no-creep performance lets you place your equipment wherever you wish without bolting it to the floor and to move it easily without re-anchoring or re-shimming.

Even when immersed in oil, water or other hazards, the high strength steel housing and neoprene base resist failure for years of daily punishment.

We offer six standard load ranges to closely match your weight and dimensional requirements. Punch presses, milling machines, injection molding equipment, lathes, compressors, mixers...any equipment that generates motion internally or is affected by external vibration can be economically mounted for top performance plus complete portability.

Leveling is simple and quick with internal adjustment capability up to 1/2 inch above loaded height, just by a few turns of the leveling bolt. Then the locknut is tightened on the machine foot for a permanent, precise mount.

Features and Benefits:

- Easy Leveling
- Reduce Installation and Relocation Costs
- No Special Foundations
- Isolate Shock and Vibration
- Reduce Noise Levels
- Meets OSHA anchoring Standards
- Reduce Maintenance Costs
- Improve Production Efficiency
- Approximately 8-12 Hz Natural Frequency at Max. Load
- Special Bolt Lengths, Diameters, and Reducer Bushings Available

Applications:

- Injection Molding Machines
- Die Casting Machines
- Punch Presses
- Lathes
- Grinders
- Jig Borers
- Screw Machines
- Milling, Machines
- Brakes
- Four Slides
- And many others.

Machine Leveling Mounts

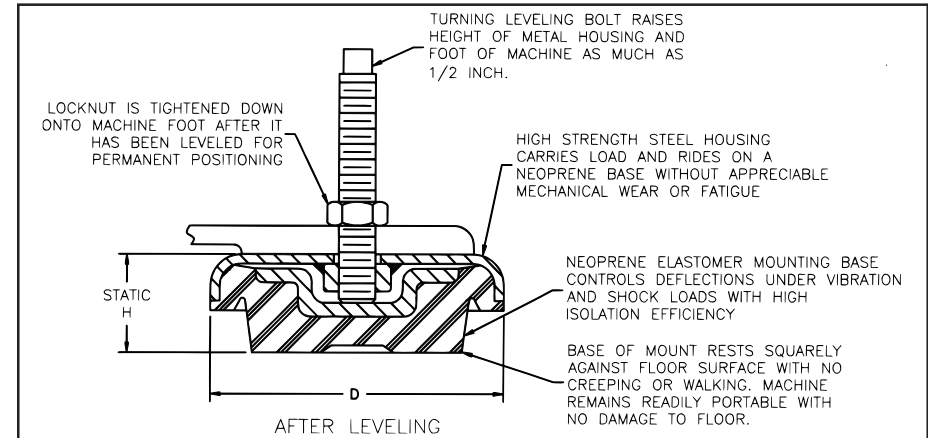

Part No.	Min. Load (lbs.)	Max. Load (lbs.)	Bolt Size x Length (in.)	D (in.)	Static Height (in.)
52220	30	150	3/8-16 x 3	3.13	1.50
52221	55	250	3/8-16 x 3	3.13	1.50
52221-1	100	500	3/8-24 x 3	3.13	1.50
52222	100	500	3/8-16 x 3	3.13	1.50
52223*	300	1000	1/2-13 x 5	4.75	1.50
52224	300	1000	1/2-13 x 5	4.75	1.50
52225*	500	4500	3/4-10 x 5	6.25	1.63
52226	500	4500	3/4-10 x 5	6.25	1.63
52227*	4000	13000	1-14 x 8	9	2.50
52229*	4000	13000	1-14 x 8	9	2.25
52231	4000	13000	3/4-10 x 4	9	2.25
52232	4000	13000	3/4-10 x 8	9	2.25

Metric Series

Part No.	Min. Load (kgs.)	Max. Load (kgs.)	Bolt Size x Length (mm)	D (mm)	Static Height (mm.)
52221-1-M10	45	230	M10x1.5 x 80	80	38
52224-M12	135	450	M12x1.75 x 130	120	38
52226-M20	230	2040	M20x2.5 x 130	160	41
52229-M24	1815	5900	M24x3.0 x 180	230	57
52248-M30*	3500	11500	M30x3.5 x 200	315	70

Normally Supplied with hex head bolt. (*) indicates square head bolts