

507 Series Mounts

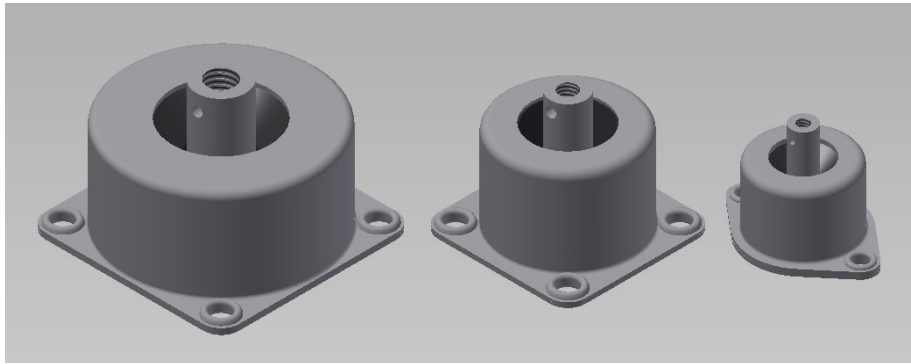

Tech Products' 507 Series Mounts are general purpose isolators for equipment mounted in aircraft, shipboard, or vehicular applications.

These mounts are designed to isolate high frequency vibration and the high damped silicone elastomer provides good shock attenuation and low resonant amplification. The three different sizes are designed to support load ranges from 1 to 80 lbs.

- Fail-Safe, All-Attitude Design
- 1:1 Axial to Radial Stiffness
- Isolation of Vibration over 40 Hz
- 4.0 Max. Transmissibility at Resonance
- High Damped Silicone Elastomer
- -80°F to 300°F Temperature Range

50722 Series

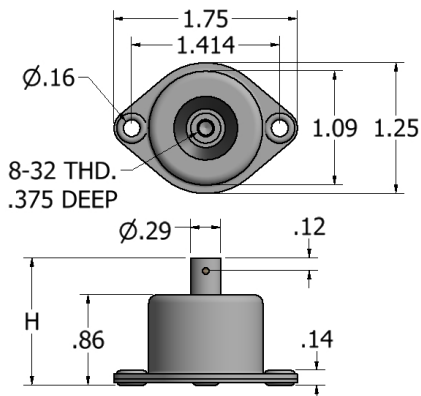

Part Number	Max. Load (lbs.)
50722-1	1
50722-2	2
50722-3	3
50722-5	5

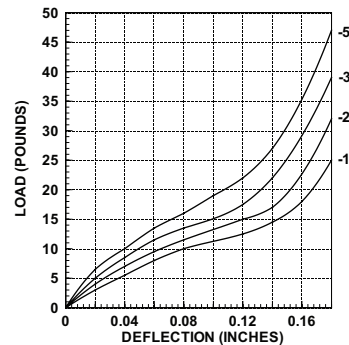

	Height (H)
Compressed	0.91
Approx. Free	1.22
Max. Extended	1.56

507 Series Mounts

50744 Series

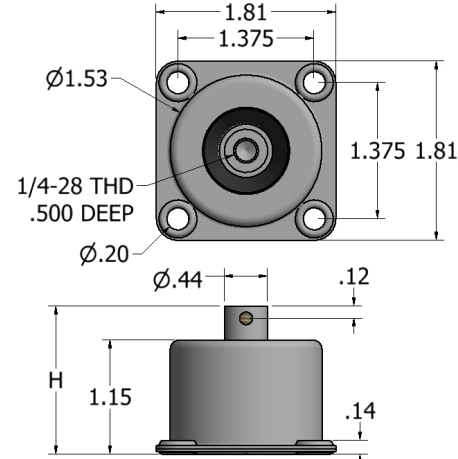

Part Number	Max. Load (lbs.)
50744-10	10
50744-15	15
50744-20	20

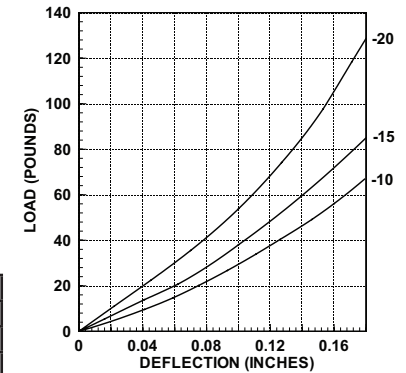

	Height (H)
Compressed	1.19
Approx. Free	1.50
Max. Extended	1.88

50764 Series

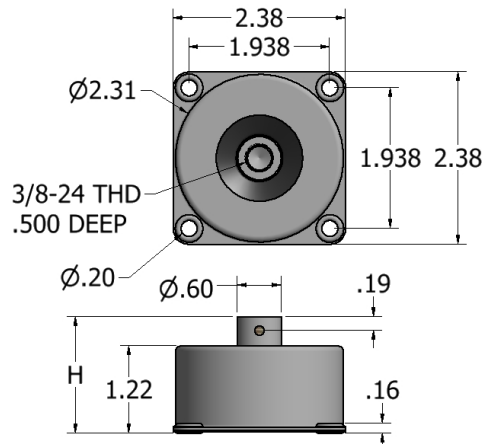

Part Number	Max. Load (lbs.)
50764-35	35
50764-50	50
50764-80	80

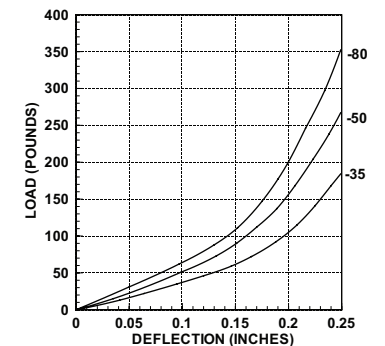

	Height (H)
Compressed	1.25
Approx. Free	1.62
Max. Extended	1.94