

Fail-Safe Compression Mounts

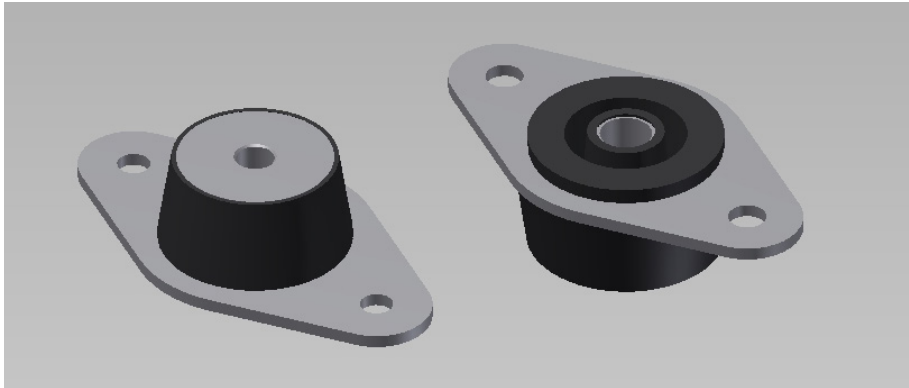

These fail-safe isolators are ideal for isolation of diesel engines and generators used in construction equipment, recreational vehicles and off-road equipment. The low natural frequency allows them to be used for computer and electronic equipment when there is a need for a "ruggedized" installation. They are also excellent isolators for compressors, motors, pumps and other machinery when skid mounted.

- Three sizes available for load ranges of 50 to 550 lbs.,
- High stiffness ratio of 6:1, axial-to-radial.
- Standard elastomer is neoprene,
- Resistant to ozone, fuel and oils.
- Temperature range of -20°F to $+180^{\circ}\text{F}$.
- Optional materials such as nitrile, butyl, silicone and others are available to meet your environmental conditions or military specifications.
- These mounts are fail-safe when used with snubbing washers and installed as shown. See page 75 for snubbing washers.

Part No.	Axial Static Load Rating: Nominal (lbs)	Color Code
51700-1	50	Yellow/Gold
51700-3	90	Red/Gold
51700-5	150	Green/Gold
51700-7	215	Blue/Gold
51700-9	300	White/Gold
51641-2	100	Yellow/Gold
51641-4	155	Red/Gold
51641-6	230	Green/Gold
51641-8	320	Blue/Gold
51641-10	420	White/Gold
51716-2	120	Yellow/Gold
51716-4	185	Red/Gold
51716-6	250	Green/Gold
51716-8	400	Blue/Gold
51716-10	550	White/Gold

INSTALLATION

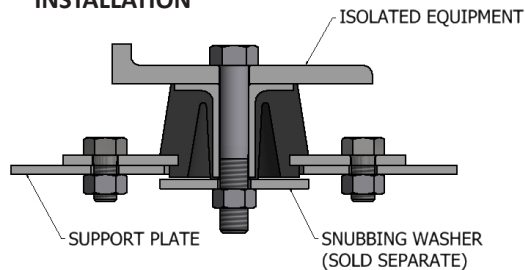

Fail-Safe Compression Mounts

51700 Series

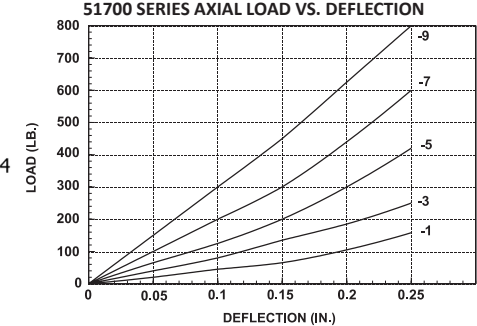
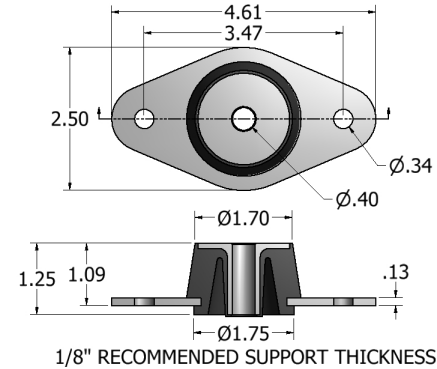

51641 Series

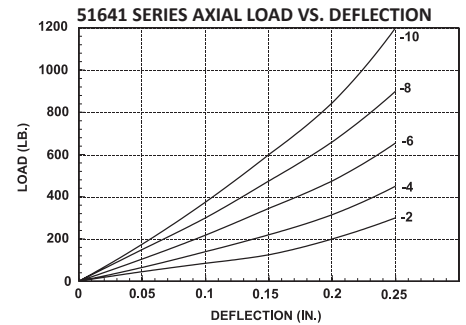
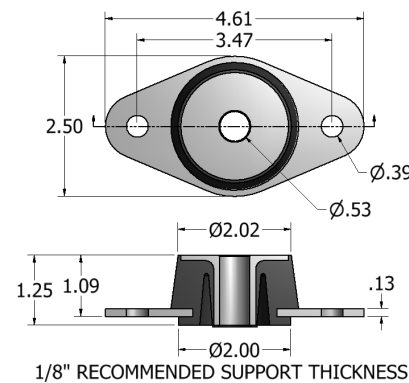

51716 Series

