

Ring and Bushing Mounts

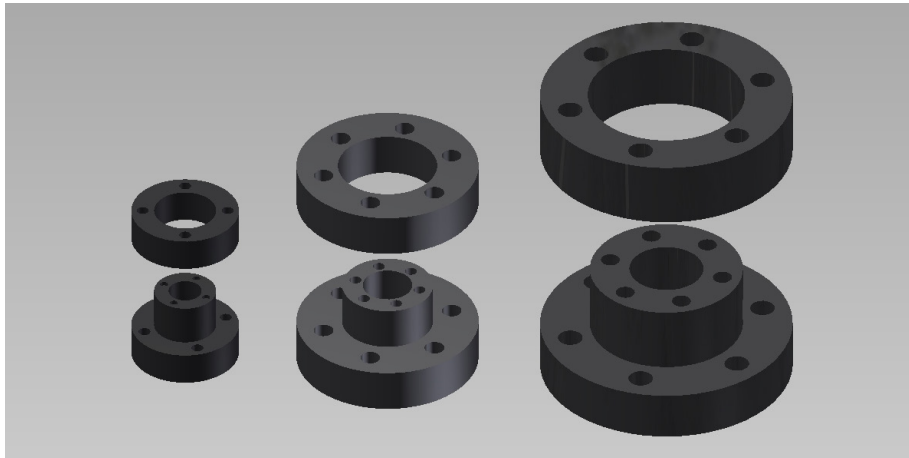

Neoprene Ring and Bushing Mounts are incorporated directly into the structural components of equipment such as office machines, motors and pumps, as well as air conditioning, electronic and scientific equipment. They offer fail-safe operation when installed in pairs.

Opposing holes in the elastomer provide excellent low-frequency isolation. The location of the holes cushions shock and isolates vibration parallel to the mount axis. The bushing's holes isolate vibration perpendicular to its axis.

Features

- Fail-Safe installation when proper snubbing washers and spacers are used
- Neoprene elastomer resistant to oil, fuel, and solvents
- Three sizes for loads ranging from 1 to 100 lbs.
- Operating temperature range of -20°F to 180°F

Typical Mounting Application

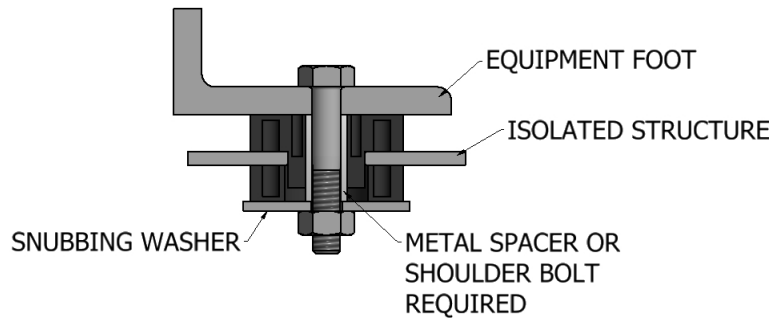

Ring and Bushing Mounts

